

NorMar Boom Reels Containerized

Oil Spill *Response Equipment*

The NorMar containerized boom reels are built from coated mild steel, with hot dip galvanized centre pipe.

The reels are powered by hydraulic motor mounted on a reduction gearbox with brake. The reels are mounted in standard ISO containers. The 5 m³ are delivered in 10 ft containers and 8, 10 and 12 m³ in 20ft containers.

The systems are complete with hydraulic power pack mounted in a noise reduced separate room.

The reels may be delivered with an air filling connection for automatic inflation of the oil boom

The reels are sandblasted, painted with 3 layers to a thickness of 335 my. Standard colour is red – RAL 3020

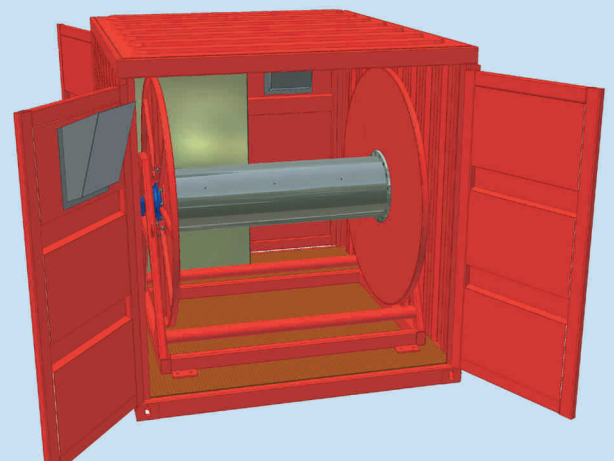

NorMar Boom Reels

Containerized

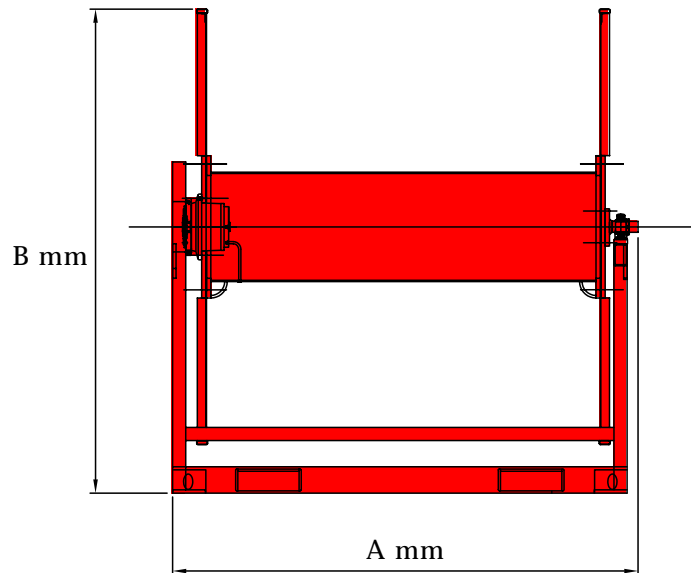
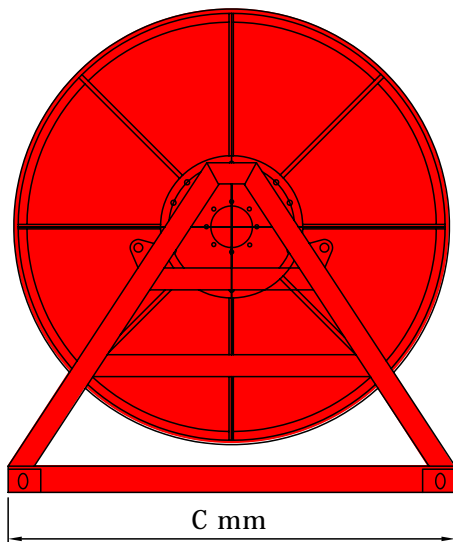

Reel Volume	A mm	B mm	C mm	Material Weight	Weight Approx
5 m ³	2126	2211	2042	Coated Mild Steel	950 kg
8 m ³	2500	2300	2042	Coated Mild Steel	1250 kg
10 m ³	3500	2300	2042	Coated Mild Steel	1450 kg
12 m ³	3900	2300	2370	Coated Mild Steel	1580 kg

In addition comes the weight of the container and power pack.



Manufacturer

NOREN Bergen AS, Sørehavnv. 41, 5179 Godvik - Norway

Phone: +47 55 50 86 70 Mail: post@noren.no
 Fax: +47 55 50 86 71 Web: www.noren.no

World wide distributor

AllMaritim AS, P.O. Box 51, 5812 Bergen, NORWAY

Phone: +47 55 33 61 60 Mail: post@allmaritim.com
 Fax: +47 55 33 61 61 Web: www.allmaritim.com

