

NorMar

Boom Reels

Standard

Oil Spill *Response* *Equipment*

The NorMar boom reels are built from coated mild steel, with hot dip galvanised centre pipe. The reels are powered by hydraulic motor mounted on a reduction gearbox with brake. The reels are complete with hydraulic operating valves and quick couplings for easy hook-up to a vessel's central hydraulic system, or an independent hydraulic power pack.

The reels may be delivered with an air filling connection for automatic inflation of the oil boom

The reels are sandblasted, painted with 3 layers to a thickness of 335 μ m. Standard colour is red – RAL 3020

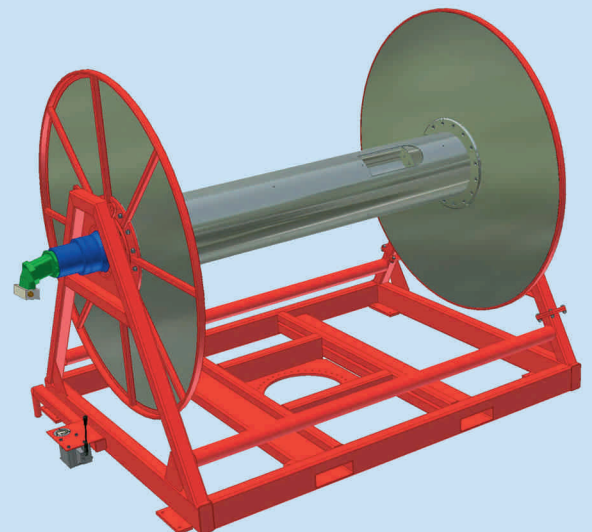

NorMar Boom Reels Standard

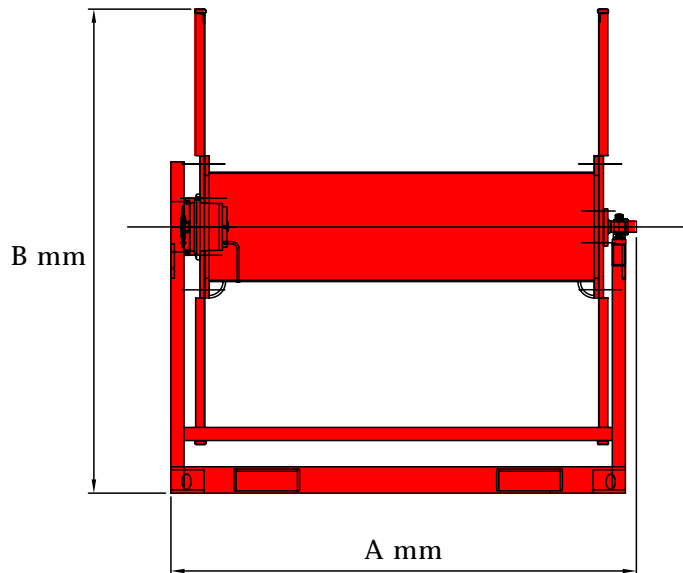
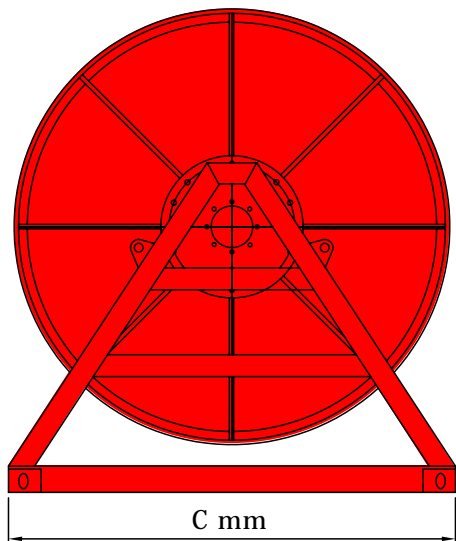

Reel Volume	A mm	B mm	C mm	Material	Weight Approx
5 m ³	2126	2211	2042	Coated Mild Steel	950 kg
8 m ³	2500	2300	2042	Coated Mild Steel	1250 kg
10 m ³	3000	2490	2042	Coated Mild Steel	1450 kg
12 m ³	3300	2595	2370	Coated Mild Steel	1580 kg
14 m ³	3505	2995	2370	Coated Mild Steel	1650 kg
16 m ³	4000	2595	2370	Coated Mild Steel	1800 kg
18 m ³	4000	2695	2370	Coated Mild Steel	2100 kg



Manufacturer

NOREN Bergen AS, Sørehavnv. 41, 5179 Godvik - Norway

Phone: +47 55 50 86 70 Mail: post@noren.no
Fax: +47 55 50 86 71 Web: www.noren.no

World wide distributor

AllMaritim AS, P.O. Box 51, 5812 Bergen, NORWAY

Phone: +47 55 33 61 60 Mail: post@allmaritim.com
Fax: +47 55 33 61 61 Web: www.allmaritim.com

